

**Reviewed and Revised June 2010**  
**EXHIBIT III to GENERAL RULES OF G19YFL**  
**6-3-2 DEFENSE for 8/9 Year Olds**

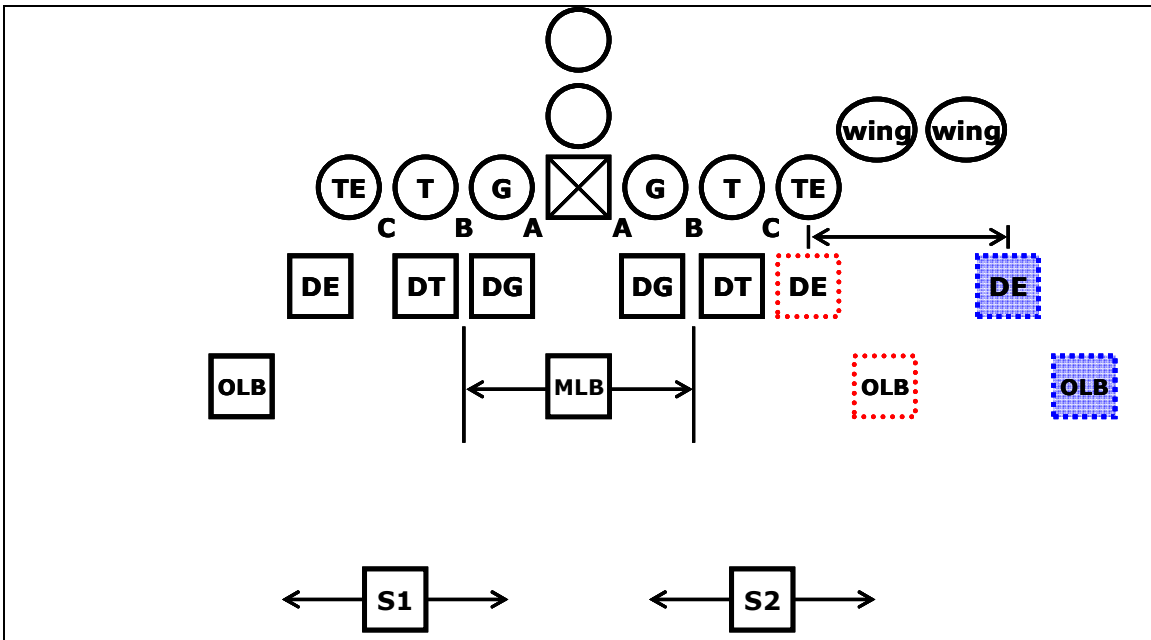

Figure 1. TE to defense's left w/ TE and 2 wings to defense's right.

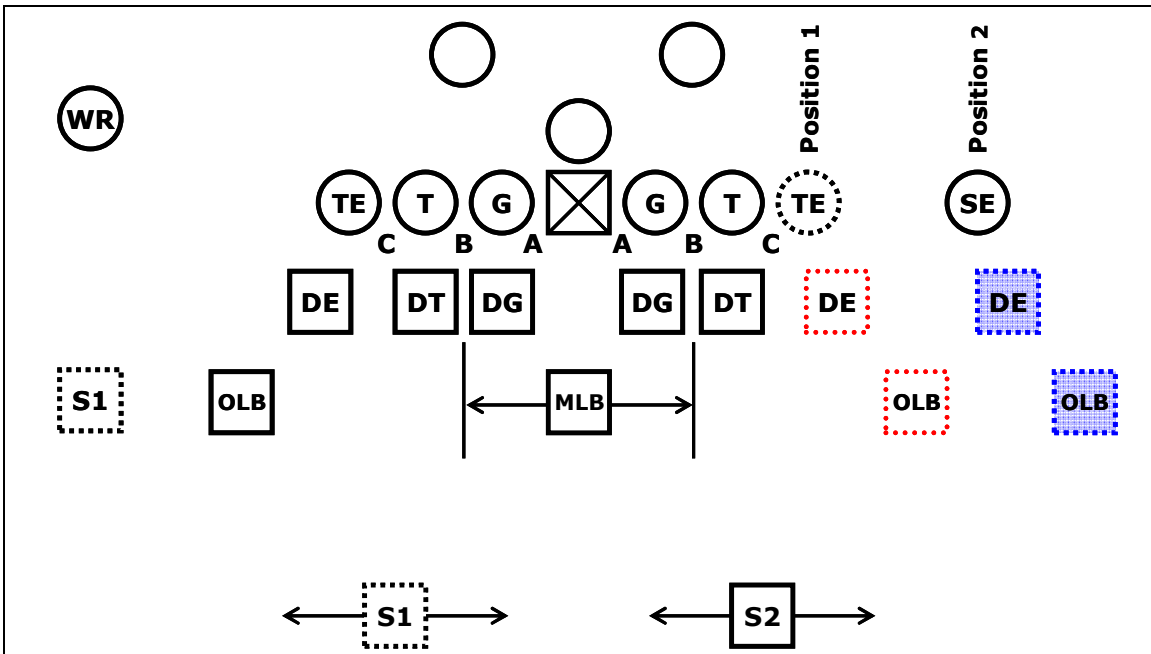

Figure 2. TE and WR to defense's left with SE to defense's right.

## Reviewed and Revised June 2010

### Offensive Line

- The maximum split for all OL positions will be fingertips-to-fingertips.
- The line must be balanced with three players on either side of the center.
- OL are permitted to pull at all ages.

### Defensive Line

- DGs and DTs must align head-up with their OL counterparts. DGs and DTs cannot line up in a 2-point stance and must be on the line of scrimmage (LOS).
- DEs and DTs are permitted to shoot the “B” gaps. DEs and DTs are permitted to loop and/or stunt.
- DL are permitted to shoot the “A” gap. However, they are not permitted to hit the center until he establishes himself as a blocker by completing the snap and has sufficient time to get into a blocking position.
- DEs are permitted to line up anywhere from head up or outside shoulder of a TE to the outside shoulder of the widest wing to his side (refer to Figure 1). If a SE is used, the DE can line up as if a TE was still there (refer to Figure 2, Position 1) or he may align head up or outside shoulder of the SE (refer to Figure 2, Position 2).

A **wing** is defined as a player off the line of scrimmage and within 2 fingertips-to-fingertips reach of the TE or 2 fingertips-to-fingertips reach of the tackle if a SE is used.

A TE becomes a **SE** when he aligns further than fingertips-to-fingertips reach from the OT.

### Defensive Backfield

- All LBs must be at least 2 yards from the LOS. The MLB may line up anywhere from “B” gap to “B” gap.
- OLBs must be a minimum of 1 yard off the outside shoulder of the DE regardless of where the DE lines up. There is no maximum to the outside; an OLB can spread as wide as desired.
- Safeties may play inside or outside the OLB, but they must be at least 6 yards off the LOS. On or within the 10-yard line of the defense, the safeties may be moved up as close as 3 yards from the LOS. If the offense uses a WR, the defense may use a CB instead of a safety. The CB must be lined up at least 2 yards off the LOS.

A **WR** is defined as any player **off the LOS** and more than 2 fingertips-to-fingertips reach of the TE or more than 2 fingertips-to-fingertips reach of the OT if the offense uses a SE.

- LB's and DB's are NOT permitted to cross the LOS until either the ball is handed off to a RB or WR or the QB carries the ball outside the OTs.
- BLITZING IS NOT PERMITTED!!!

#### NOTES:

- (i) On or within the 10-yard line of the defense, a “Gap-8” defense may be used.
- (ii) An offensive player who is off the LOS and to the outside of the TE is considered to be either a wing or a WR. There is no “gray area”. As such, the defense must be allowed to line up accordingly.

**Reviewed and Revised June 2010**  
**8/9 Offensive Formations**

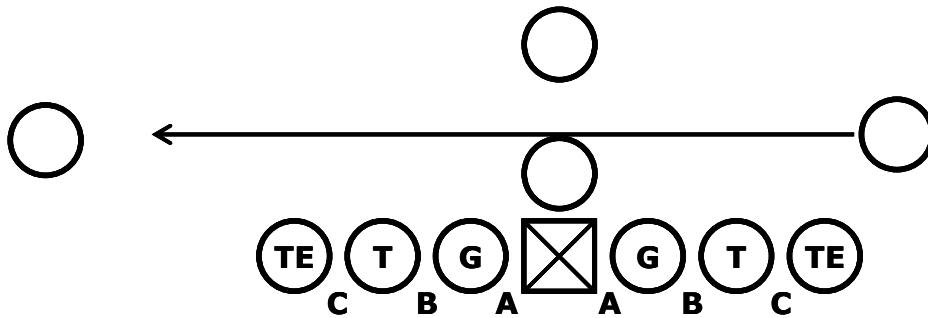

The above formation has a wing on the left and either a wing on the right or a receiver lined up wide right. The wing on the left goes in motion and is past the midline when the ball is snapped. This is a **legal formation** as long as the running back in the back field is lined up behind the QB and does not cross the midline.

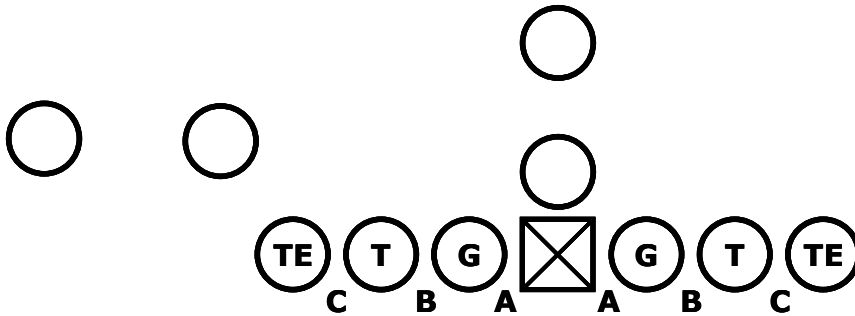

The above formation is a **legal formation** provided the running back in the back field is lined up behind the QB and does not cross the midline.

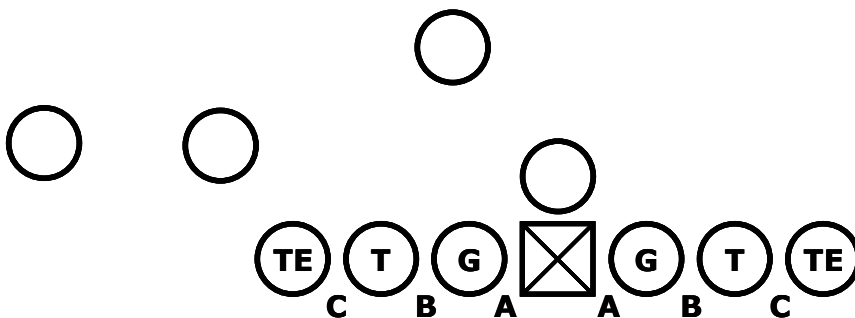

The above formation is considered trips and is an **illegal formation** because the running back is beyond the midline.